



Rev	Date	Description

ALL DIMENSIONS IN (mm)
UNLESS OTHERWISE SPECIFIED
BREAK ALL SHARP EDGES

TOLERANCES
(BEFORE PAINTING
& AFTER PLATING)
X ± 1.00
X.X ± 0.50
X.XX ± 0.10
ANGLES ± 0.5°

A01- RENDER
CLIENT: RFA1000
PROJ. NO.: TBA
PART NO.: --
Revision --
Page 1

600mm(W)x1515mm(H)x270mm(D) DOUBLE SIDED GONDOLA BAY- NON PERFORATED		
START BAY WITH SKIRT DRAWER (MATTE BLACK)		
PRODUCT CODE: RFA1083	Date: 16/06/2023	DO NOT SCALE
Drawn by	DH	
Checked by	--	
		Scale@A3 1:20

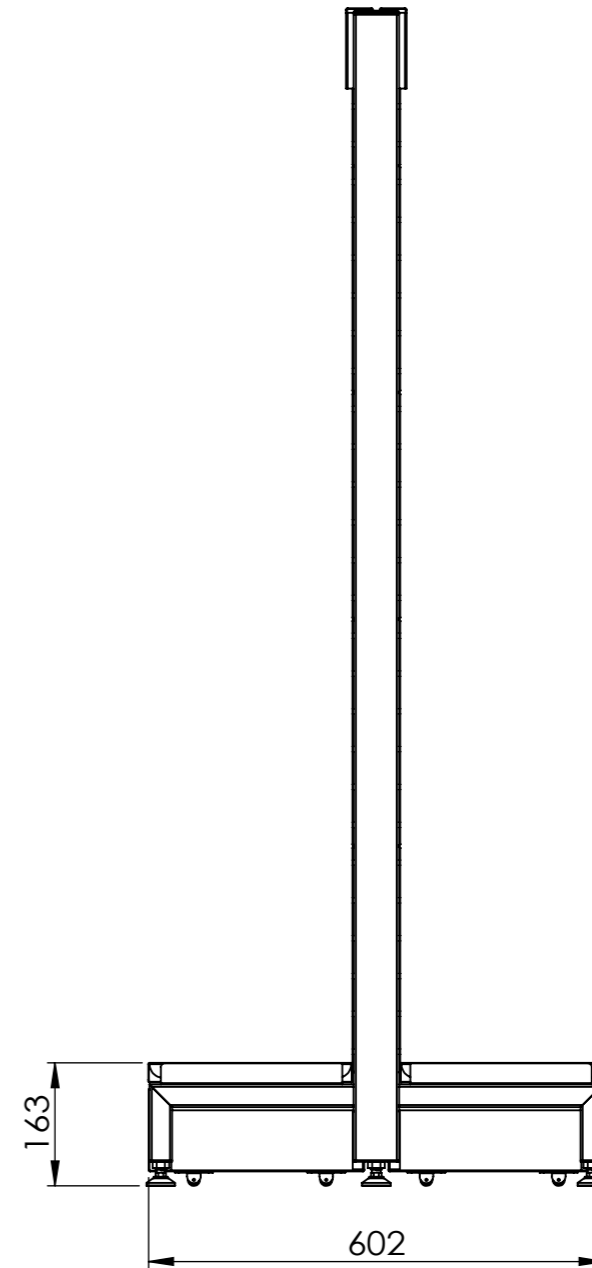
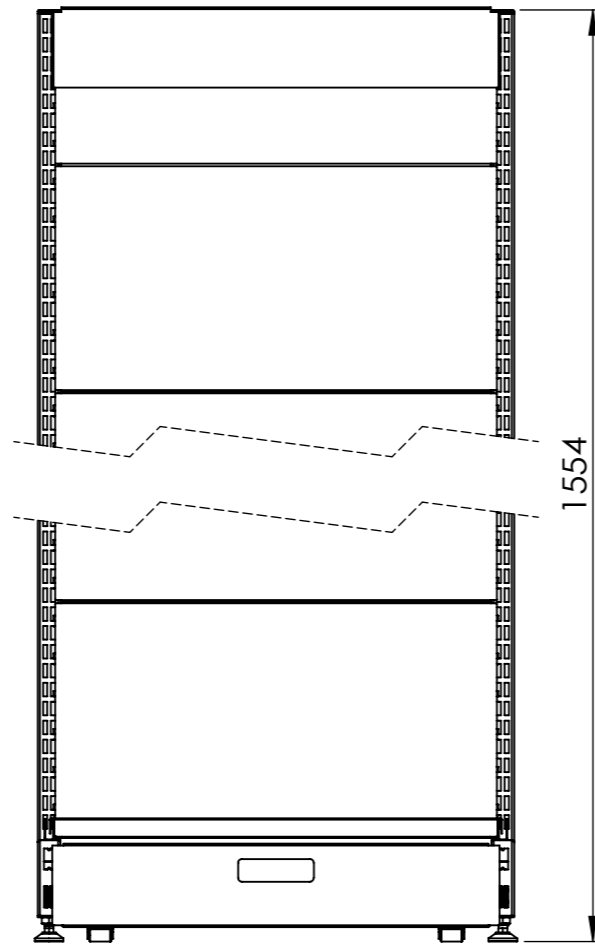
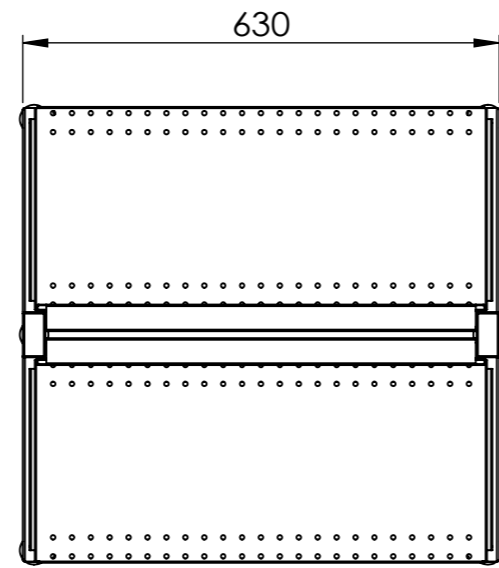
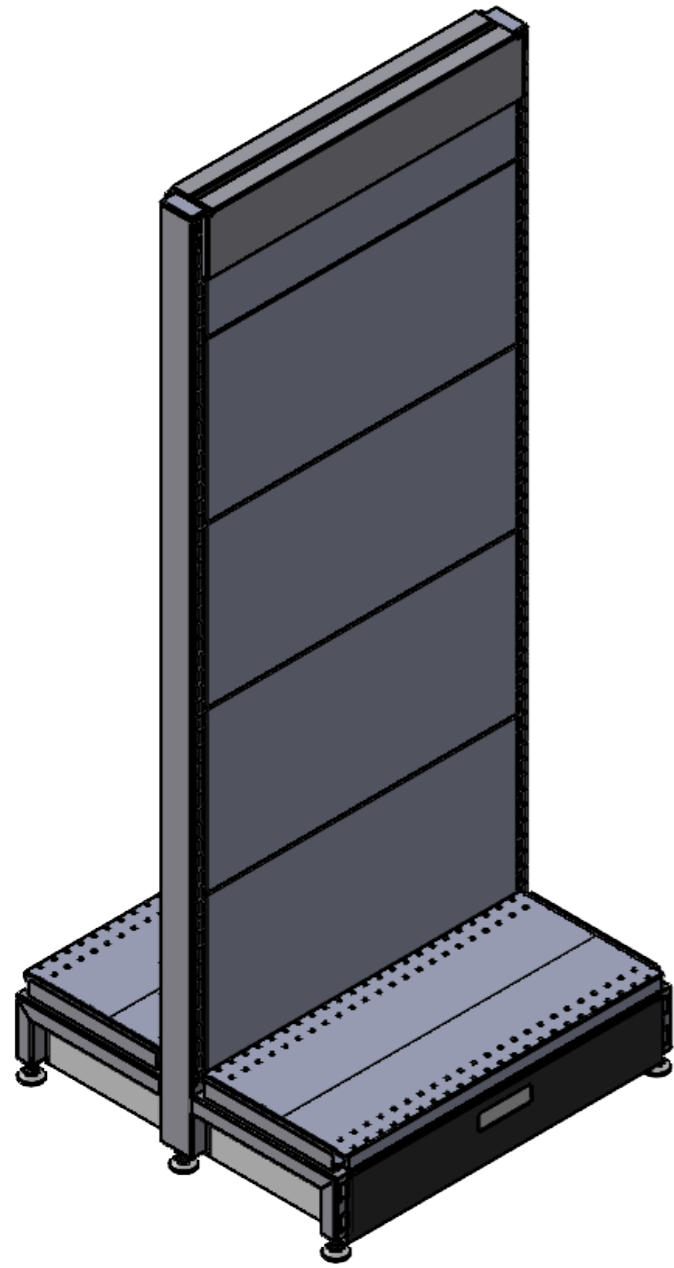

Rev	Date	Description

ALL DIMENSIONS IN (mm)
UNLESS OTHERWISE SPECIFIED
BREAK ALL SHARP EDGES

TOLERANCES
(BEFORE PAINTING
& AFTER PLATING)
X ± 1.00
X.X ± 0.50
X.XX ± 0.10
ANGLES ± 0.5°

A02- CLIENT

CLIENT: RFA1000

PROJ. NO.: TBA

PART NO.: --

Revision --

Page 2

600mm(W)x1515mm(H)x270mm(D) DOUBLE SIDED
GONDOLA BAY- NON PERFORATED

START BAY (MATTE BLACK)

PRODUCT CODE: **RFA1083**

Date: 16/06/2023

Drawn by DH

Checked by --

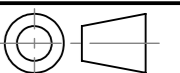

DO NOT SCALE

Scale@A3 1:15

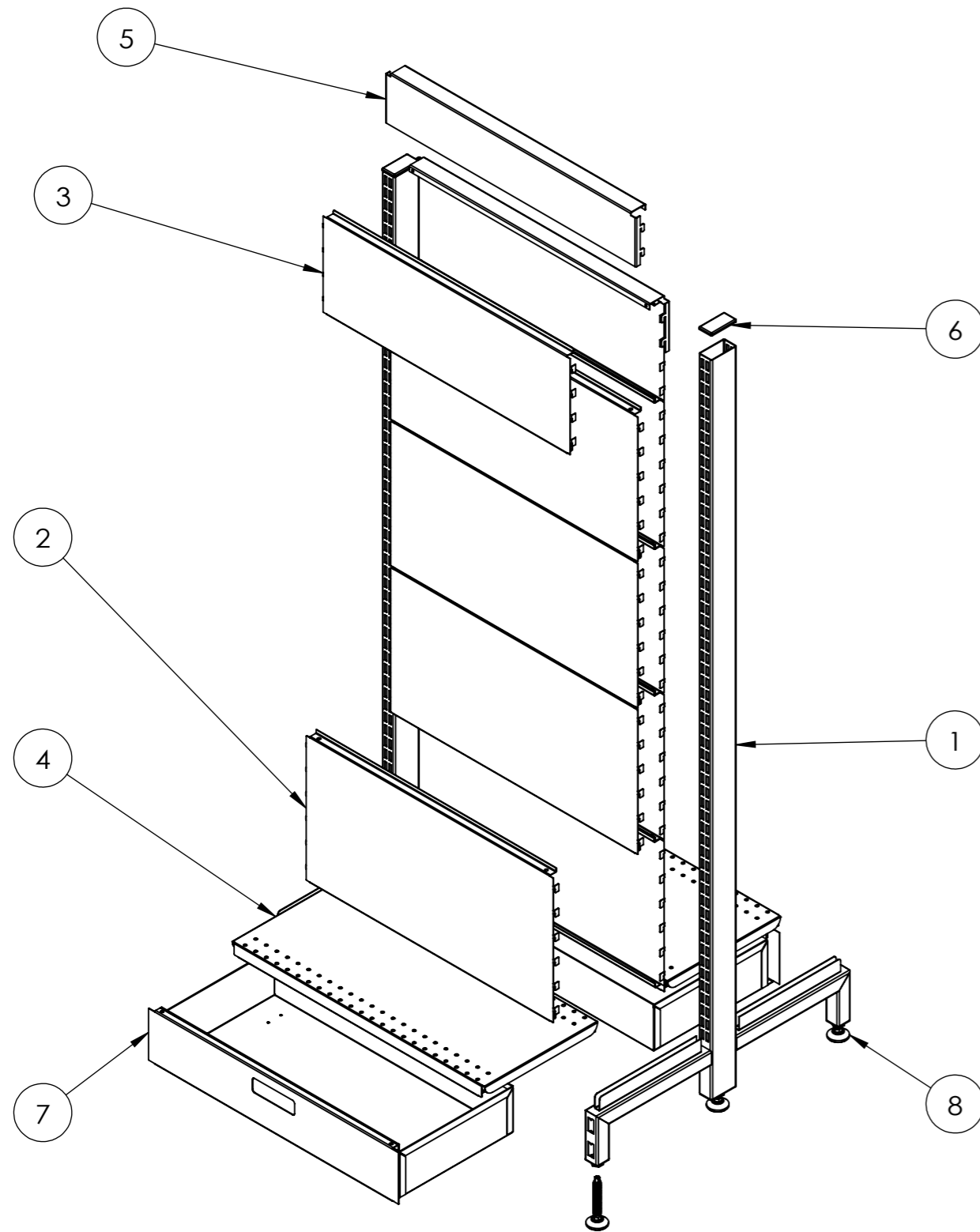

ITEM NO.	DESCRIPTION	QTY.
1	POST - DOUBLE SIDED GONDOLA - 1515 MM (H) - W/. 270 MM LEGS - PEARL WHITE	2
2	CLIP IN PANEL - 600(W) X 300(H) - NON PERFORATED - MATTE BLACK	8
3	CLIP IN PANEL - 600 MM (W) X 200 MM (H) - NON PERFORATED - MATTE BLACK	2
4	SHELF STEEL - 900 MM (W) X 270 MM (D) - BLACK	2
5	SNAP IN TOP CAP_BLACK	2
6	PLASTIC ENDCAP	2
7	SKIRT DRAWER BOX - 600mm	2
8	M12 LEVELING FEET	6

Rev	Date	Description

ALL DIMENSIONS IN (mm)
UNLESS OTHERWISE SPECIFIED
BREAK ALL SHARP EDGES

TOLERANCES
(BEFORE PAINTING
& AFTER PLATING)
X ± 1.00
X.X ± 0.50
X.XX ± 0.10
ANGLES ± 0.5°

A09- EXPLODED
CLIENT: RFA1000
PROJ. NO.: TBA
PART NO.: --
Revision --
Page 9

600mm(W)x1515mm(H)x270mm(D) DOUBLE SIDED
GONDOLA BAY- NON PERFORATED
START BAY (MATTE BLACK)

PRODUCT CODE: **RFA1083**

Date: 16/06/2023

Drawn by DH

Checked by --

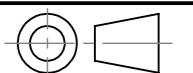

DO NOT SCALE

Scale@A3 1:20