



FINISH: P/C MATTE BLACK

AP ASSOCIATED PROJECTS COMMERCIAL BUILDERS,
PROJECT MANAGERS,
PLANNERS & DESIGNERS

T 03 8787 3000 F 03 8787 3025
48-58 Cyber Loop, Dandenong South VIC 3175

Rev	Date	Description

ALL DIMENSIONS IN (mm)
UNLESS OTHERWISE SPECIFIED
BREAK ALL SHARP EDGES

TOLERANCES
(BEFORE PAINTING
& AFTER PLATING)
X ± 1.00
X.X ± 0.50
X.XX ± 0.10
ANGLES ± 0.5°

A01- RENDER

CLIENT: RFA

PROJ. NO.: TBA

PART NO.: --

Revision --

Page 1

2000mm(W) MID PANEL CHANNEL

-

PRODUCT CODE: **RFA6120**

Date: 14/09/2023

Drawn by PS

Checked by --

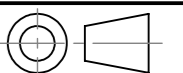

DO NOT SCALE

Scale@A3 1:10

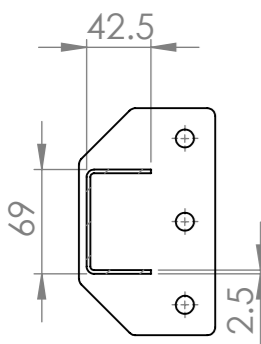
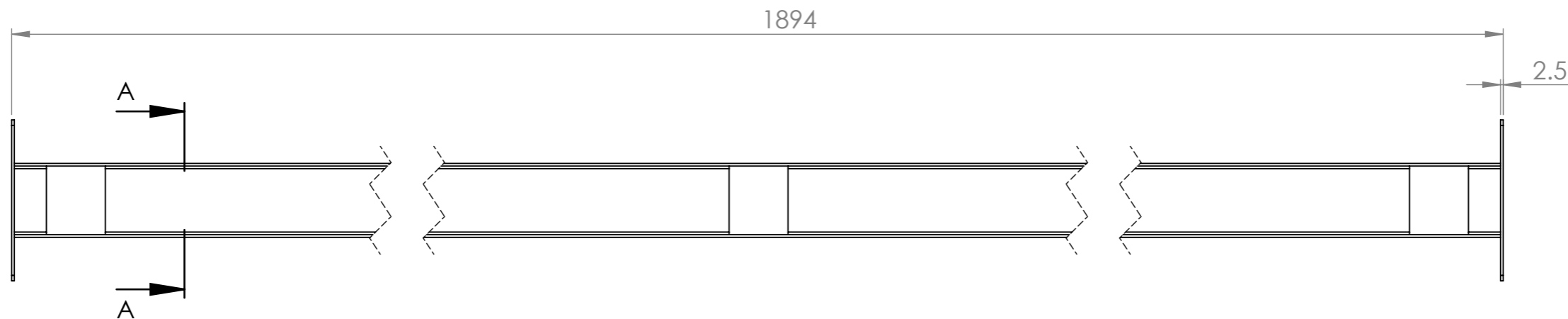
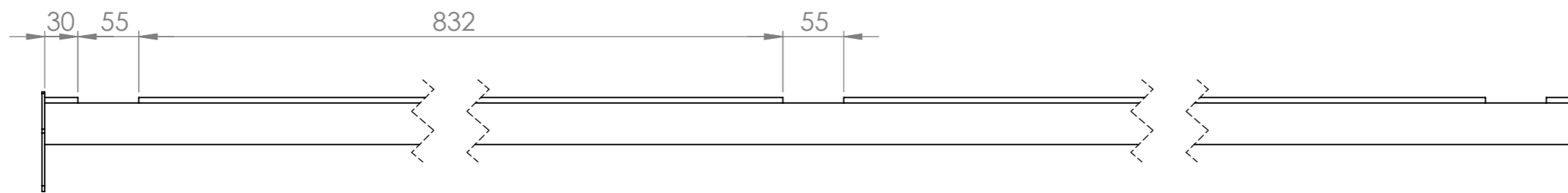
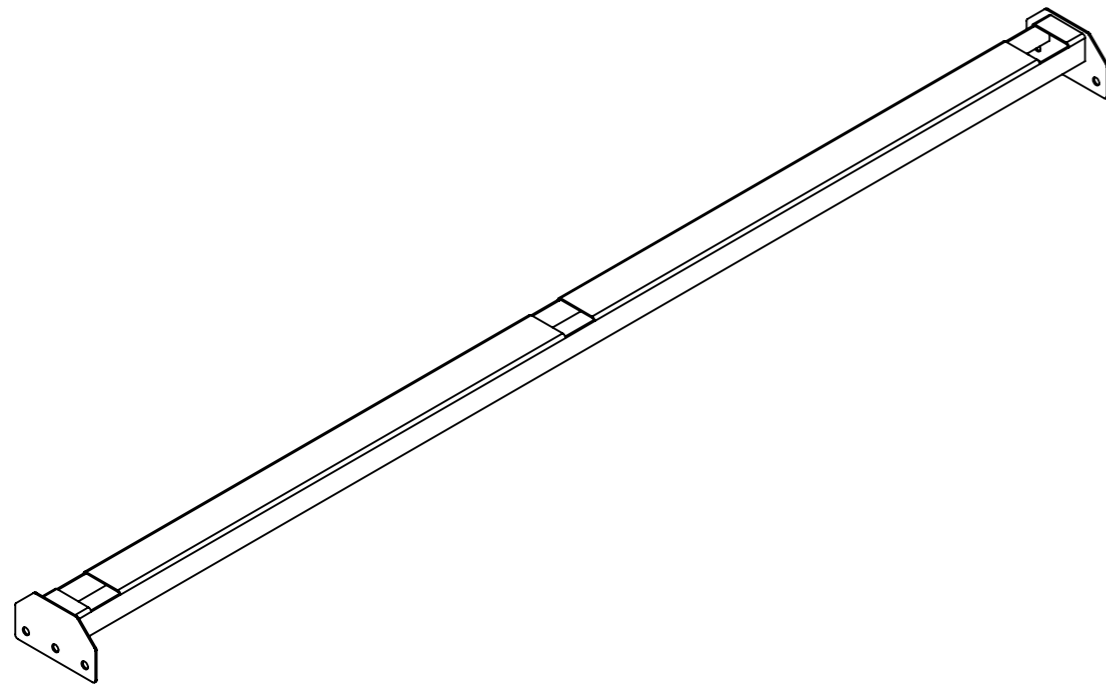

SECTION A-A

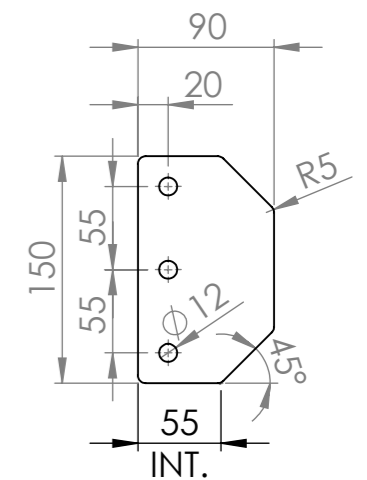

AP ASSOCIATED PROJECTS COMMERCIAL BUILDERS, PROJECT MANAGERS, PLANNERS & DESIGNERS
 T 03 8787 3000 F 03 8787 3025
 48-58 Cyber Loop, Dandenong South VIC 3175

Rev	Date	Description

ALL DIMENSIONS IN (mm)
 UNLESS OTHERWISE SPECIFIED
 BREAK ALL SHARP EDGES

TOLERANCES
 (BEFORE PAINTING
 & AFTER PLATING)
 X ± 1.00
 X.X ± 0.50
 X.XX ± 0.10
 ANGLES ± 0.5°

A02- DIMENSIONS
 CLIENT: RFA
 PROJ. NO.: TBA
 PART NO.: --
 Revision --
 Page 2

2000mm(W) MID PANEL CHANNEL		
PRODUCT CODE: RFA6120	Date: 14/09/2023	
Drawn by PS	Checked by --	DO NOT SCALE
Scale@A3 1:5		