

FINISH: P/C MATTE BLACK

AP ASSOCIATED PROJECTS COMMERCIAL BUILDERS,
PROJECT MANAGERS,
PLANNERS & DESIGNERS

T 03 8787 3000 F 03 8787 3025
48-58 Cyber Loop, Dandenong South VIC 3175

Rev	Date	Description

ALL DIMENSIONS IN (mm)
UNLESS OTHERWISE SPECIFIED
BREAK ALL SHARP EDGES

TOLERANCES
(BEFORE PAINTING
& AFTER PLATING)
X ± 1.00
X.X ± 0.50
X.XX ± 0.10
ANGLES ± 0.5°

A01- RENDER

CLIENT: RFA

PROJ. NO.: TBA

PART NO.: --

Revision --

Page 1

900mm(W) x600mm(D) SHELF

PRODUCT CODE: **RFA6128**

Date: 15/09/2023

Drawn by PS

Checked by --

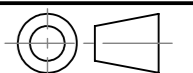

DO NOT SCALE

Scale@A3 1:10

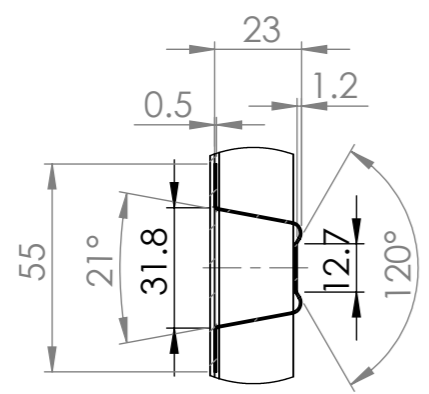
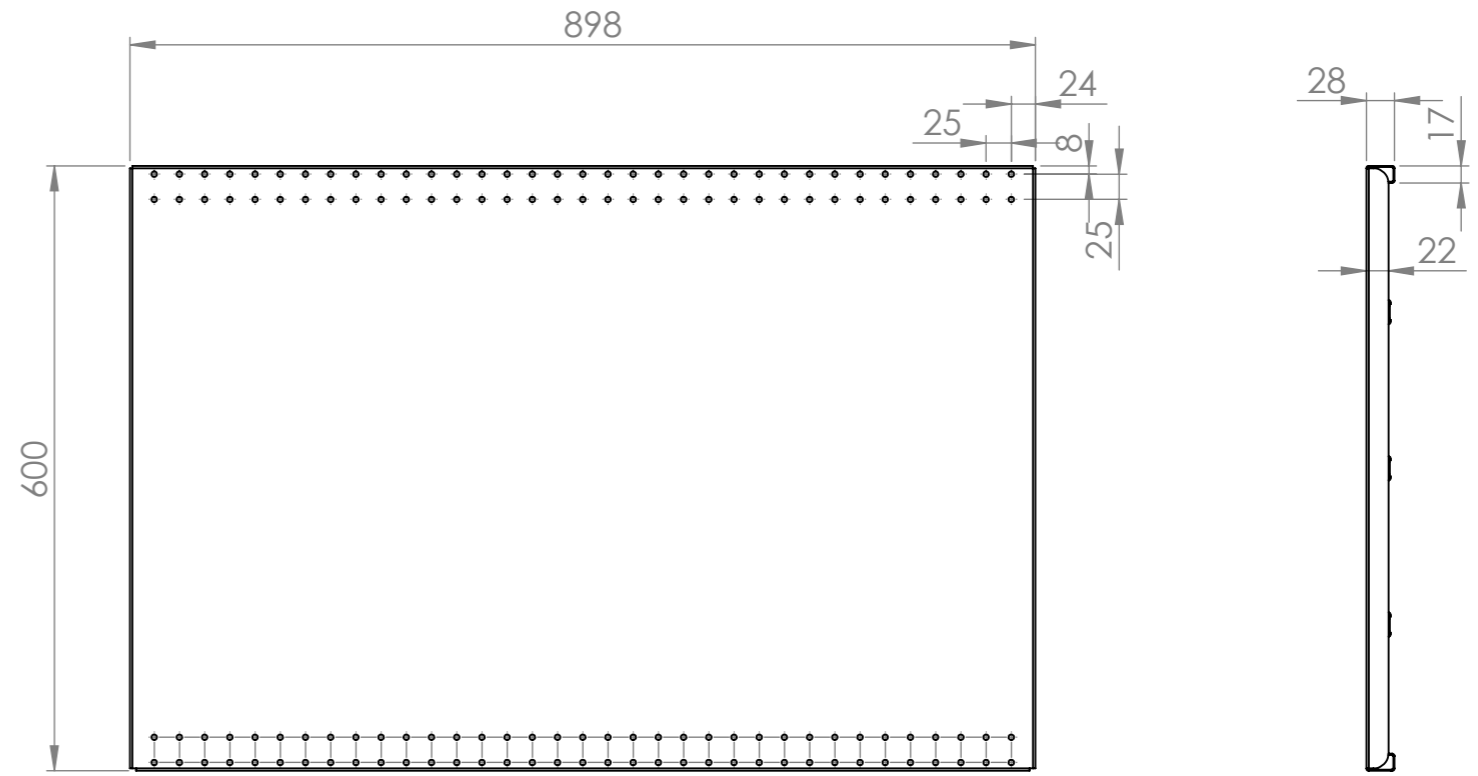
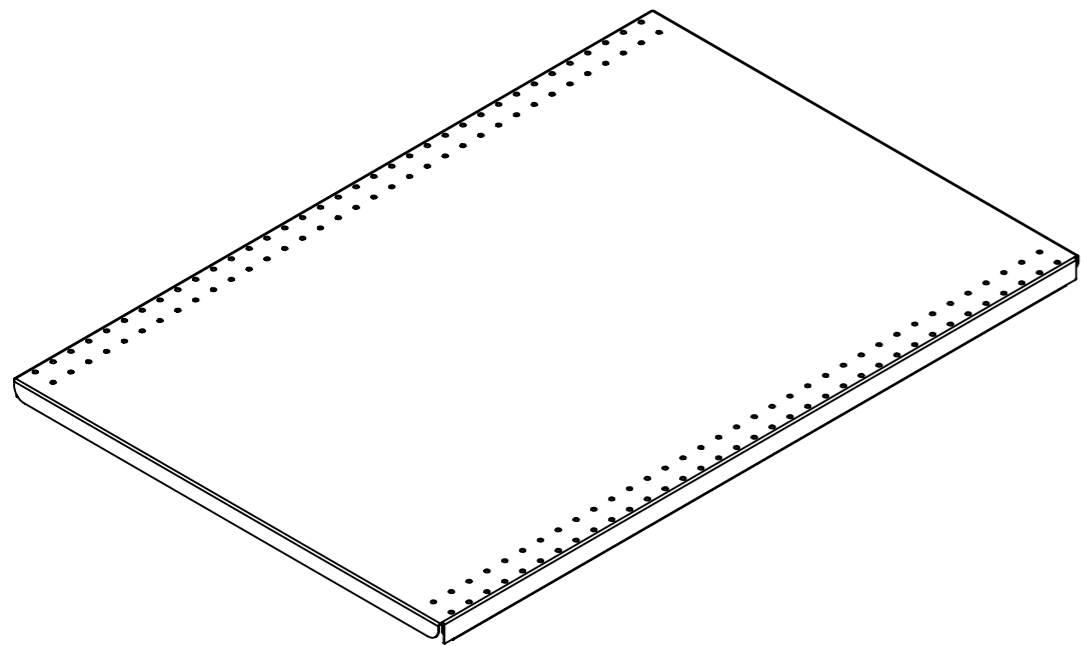

DETAIL B
SCALE 1 : 2

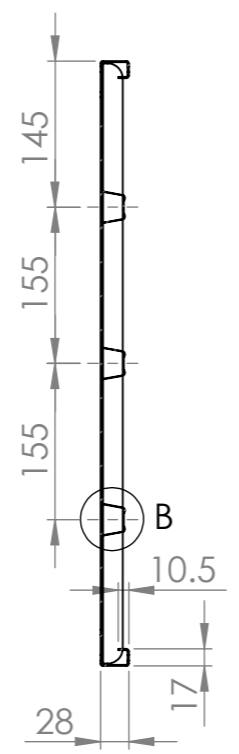

SECTION A-A

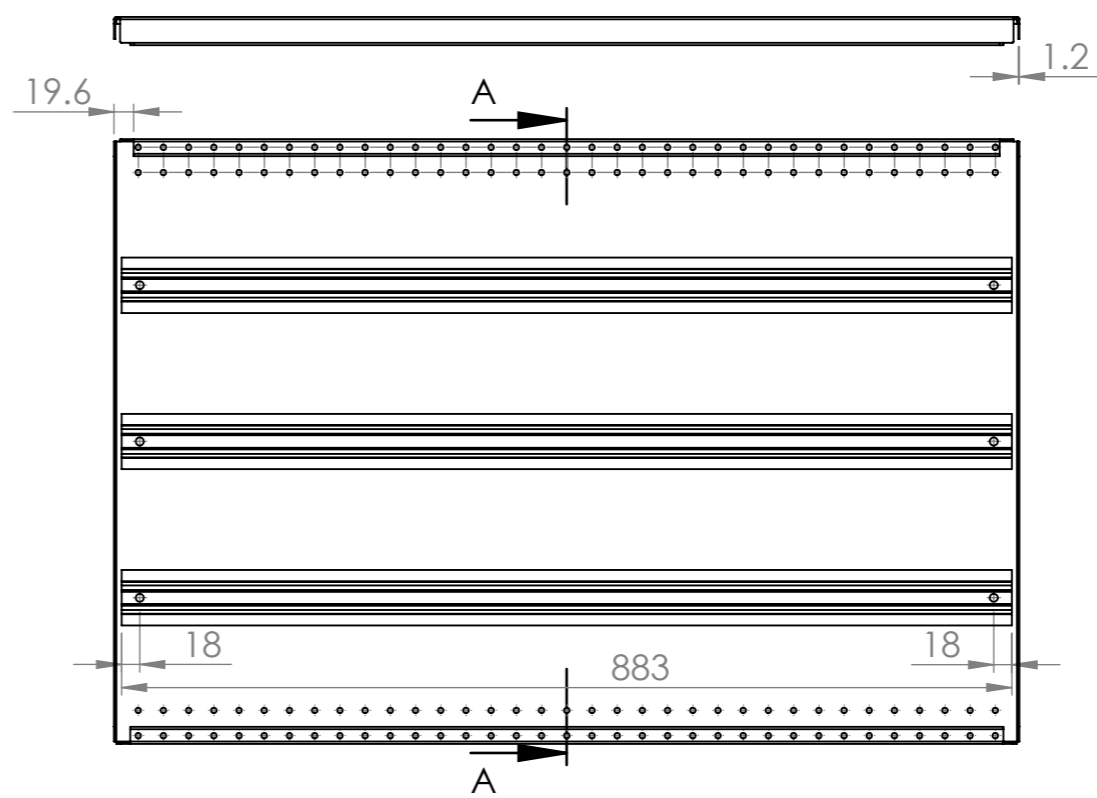

AP ASSOCIATED PROJECTS COMMERCIAL BUILDERS,
PROJECT MANAGERS,
PLANNERS & DESIGNERS

T 03 8787 3000 F 03 8787 3025
48-58 Cyber Loop, Dandenong South VIC 3175

Rev	Date	Description

ALL DIMENSIONS IN (mm)
UNLESS OTHERWISE SPECIFIED
BREAK ALL SHARP EDGES

TOLERANCES
(BEFORE PAINTING
& AFTER PLATING)
X ± 1.00
X.X ± 0.50
X.XX ± 0.10
ANGLES ± 0.5°

A02- DIMENSIONS
CLIENT: RFA
PROJ. NO.: TBA
PART NO.: --
Revision --
Page 2

900mm(W) x 600mm(D) SHELF		
PRODUCT CODE: RFA6128		
Date:	15/09/2023	DO NOT SCALE
Drawn by	PS	
Checked by	--	
		Scale@A3 2:15